

**The Leader in
High Performance
Rocketry**

AEROTECH[®]
CONSUMER AEROSPACE

5..

4..

3..

2..

1...



**2001-2002
PRODUCT CATALOG**

A LETTER FROM GARY ROSENFELD

Welcome to AeroTech Consumer Aerospace! I want to personally thank you for taking the time to examine the wide range of products found in this catalog. I still remember the rush I experienced when I flew my first model rocket as a 14-year-old in 1969—an "Alpha" on an "A" motor.



The kits, rocket motors and accessories that you will see on these pages are the culmination of over 20 years of personal experience as well as a dedicated and ongoing team effort. Having started in 1982 with the release of its first product, the G30 composite rocket motor, AeroTech now offers a full line of high quality rocket kits, composite and hybrid propellant rocket motors, building components and ground support equipment.

AeroTech rocket kits are designed for quick assembly and are engineered to withstand the stresses of multiple high performance launches and recoveries. We introduced the reloadable hobby rocket motor in 1990, and continue to lead the industry in solid and hybrid rocket motor development. Our rocket motor line spans a wide range of performance characteristics and includes many choices from the single-use D21T to the reloadable N2000W with over 900 lbs. of peak thrust!

AeroTech has taken a proactive role in the regulatory environment that continually affects our hobby. Many of our products have evolved as a result of our success in this area, as well as from technical advances in the industry. We believe that our participation is key, and that our efforts will permit us to consistently offer a truly innovative and broadened product line to our customers for years to come.

We have set our sights towards meeting and exceeding your needs and expectations. To that end we are committed to continual enhancement to our production capacity, to expanding our professional staff, and to opening our customer service avenues as wide as possible.

I and the entire staff here at AeroTech are dedicated to assisting you in the creation and recreation of your own rocketry experience!

Gary C. Rosenfield, President, AeroTech, Inc.
October, 2000

AEROTECH WEBSITE

Launched in 1996, the AeroTech web site was created to provide a resource for customers and dealers. A customer can easily locate an authorized dealer near them by using the 'Dealers' button. Another very valuable area on the web site may be found under the 'Resources' button. The Resources area contains hundreds of downloadable Adobe Acrobat PDF documents including product instructions, order forms, and regulatory documents which can be viewed on a computer screen or printed out to paper. The 'Tour' button leads to a virtual tour of the AeroTech facility where the visitor can choose which rooms to visit and read descriptions of each office and manufacturing area. One of the newest additions to the site is the 'AeroTech Theatre,' an area containing instructional QuickTime movies to help customers to better use AeroTech products. This area is being expanded to contain short video clips of rocket launches. The 'Launches' area contains a launch calendar listing rocket club launches around the world. Check the list regularly to find a rocket launch near you!

Rocket fliers at LDRS 17, Bonneville Salt Flats, Utah



INITIATOR STARTER SET

The Initiator Starter Set is the perfect introduction to the thunderous experience of E, F, and G powered rockets. This comprehensive set of kits includes the over 3 foot tall Initiator rocket, Mantis launch pad, Interlock 12 volt launch controller, and complete illustrated assembly instructions. The Initiator Starter Set is available in two versions; one with single-use (SU) motors or with a 29mm Reloadable Motor System (RMS) E, F, G rocket motor and one each E and F reload kits for first flights.

Product No. 89001 (includes two single-use White Lightning motors)

Product No. 89002 (includes 29mm RMS E, F, G rocket motor and one each E & F White Lightning reload kits)

STARTER SET COMPONENTS

Initiator Rocket Kit

The Initiator established AeroTech's reputation for innovative and versatile advanced rocket design. Large, colorful, adhesive decals and molded plastic fins make it easy for you to achieve great looking results.

Product No. 89011

Mantis Launch Pad

The Mantis is perfect for flying both mid-power rockets (E, F, G) and small model rockets (A through D) as it accepts 1/4", 3/16" and 1/8" launch rods. Mantis makes loading a rocket easy with a swing-arm that can lower the launch rod to a horizontal position. Loaded rockets sit well off the ground for comfortable igniter hook up. Mantis is the only mid-power rocket launch pad that allows launch rod elevation and azimuth adjustments to be made without having to pick up and move the entire launcher. Mantis come with a two-piece 1/4" diameter launch rod.

Product No.: 89281

Interlock Launch Controller

A launch controller is only as good as it is safe and convenient. When armed, the Interlock controller emits a warning tone to alert spectators to a possible launch and after firing the Key Eject system automatically disarms the firing circuit for the utmost in personal protection. Our Interlock controller is conveniently designed to hook up directly to your car's 12 volt battery and to assist in placing you at a safe launch distance, incorporates 40 feet of heavy-duty power cord.

Product No.: 89381

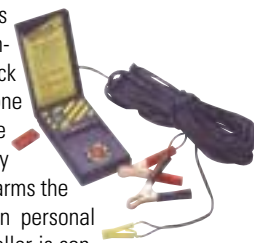
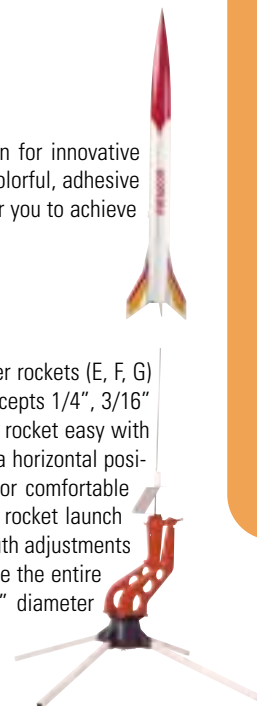

ROCKET DESIGN

AeroTech Model Rockets are different! Large size, sleek aerodynamics and adult styling single out AeroTech rockets as something special. But, take a look inside. That's where you'll find a revolution in model rocket design!

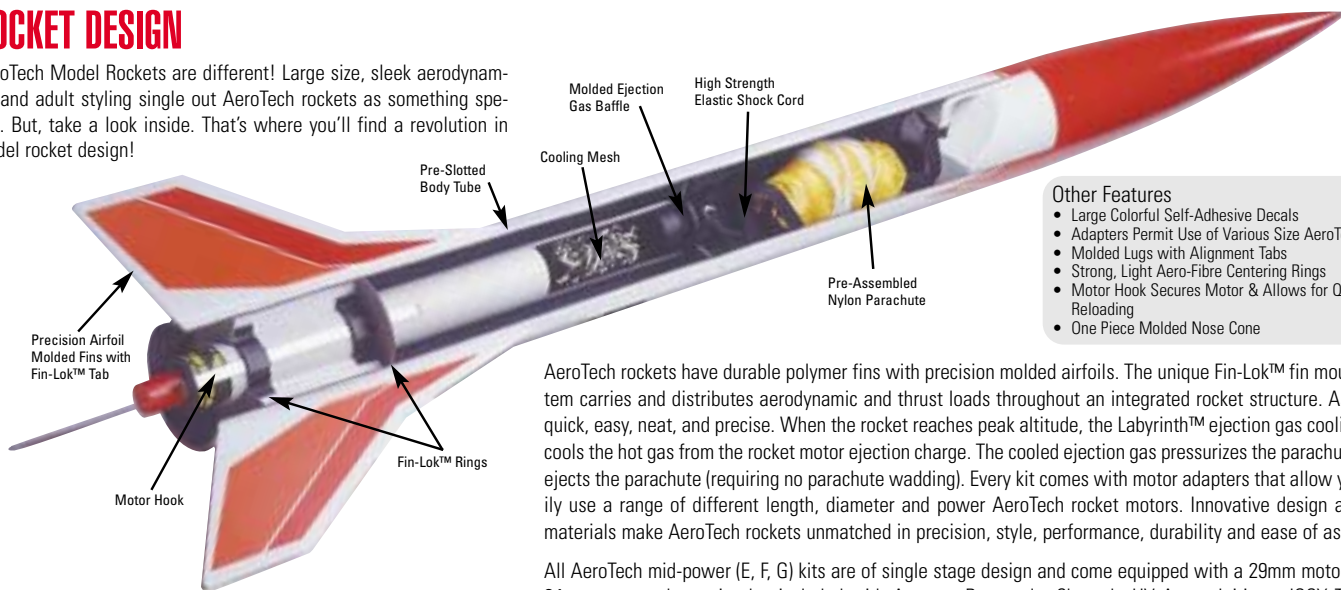

Other Features

- Large Colorful Self-Adhesive Decals
- Adapters Permit Use of Various Size AeroTech Motors
- Molded Lugs with Alignment Tabs
- Strong, Light Aero-Fibre Centering Rings
- Motor Hook Secures Motor & Allows for Quick Reloading
- One Piece Molded Nose Cone

AeroTech rockets have durable polymer fins with precision molded airfoils. The unique Fin-Lok™ fin mounting system carries and distributes aerodynamic and thrust loads throughout an integrated rocket structure. Assembly is quick, easy, neat, and precise. When the rocket reaches peak altitude, the Labyrinth™ ejection gas cooling system cools the hot gas from the rocket motor ejection charge. The cooled ejection gas pressurizes the parachute bay and ejects the parachute (requiring no parachute wadding). Every kit comes with motor adapters that allow you to easily use a range of different length, diameter and power AeroTech rocket motors. Innovative design and quality materials make AeroTech rockets unmatched in precision, style, performance, durability and ease of assembly.

All AeroTech mid-power (E, F, G) kits are of single stage design and come equipped with a 29mm motor mount. A 24mm motor adapter is also included with Arreaux, Barracuda, Cheetah, HV Arcas, Initiator, IQSY Tomahawk, Mustang, Strong Arm and Wart-Hog. All kits recover with a single nylon parachute with the exception of the Astrobe D and the Mirage which use two nylon parachutes.

INITIATOR™

Itching to fly F and G motors? The Initiator is simply the best big rocket to build first. It features molded fins, beautiful color coordinated decals, and no-wadding ejection system. An impressive 3 feet tall, the Initiator is one gorgeous rocket.

Specifications:

Length: 39"/99 cm
Diameter: 2.6"/6.7 cm
Weight (without motor):
14oz/400gms
Fins: 3
Product No. 89011

Recommended RMS Motors:

Motor	Proj. Altitude (ft/m)
E18-4W	600 / 180
E11-3J	450 / 140
E28-4T	650 / 200
F24-4W	700 / 210
F12-3J	600 / 180
F39-6T	850 / 260
E16-4W	550 / 170
E23-5T	500 / 150
F40-7W	1400 / 430
F22-5J	1050 / 320
F52-8T	1300 / 400
G33-7J	1650 / 500
G64-7W	2000 / 600

Recommended SU Motors:

Motor	Proj. Altitude (ft/m)
E15-4W	650 / 200
E30-4T	650 / 200
F20-4W*	1000 / 300
F23-4FJ*	900 / 270
F25-6W	1350 / 410
F50-6T	1450 / 440
G35-7W*	1890 / 570
G38-7FJ*	1700 / 520
G40-7W	2100 / 640
G80-7T	2000 / 600

*Econojet Motor



MUSTANG™

3,000 foot flights, striking self-adhesive graphics, molded fins, and a durable nylon parachute give the Mustang performance and value that can't be equaled in any other mid-power rocket kit.

Specifications:

Length: 32"/81 cm
Diameter: 1.9"/4.7 cm
Weight (without motor):
11oz/310gms
Fins: 4
Product No. 89010

Recommended RMS Motors:

Motor	Proj. Altitude (ft/m)
D13-4W	350 / 100
D24-4T	450 / 140
D15-4T	350 / 100
E18-7W	1000 / 300
E11-5J	750 / 230
E28-7T	1050 / 320
F24-7W	1200 / 360
F12-5J	1050 / 320
F39-6T	1450 / 440
E16-7W	950 / 290
E23-5T	800 / 240
F40-10W	2250 / 680
F22-7J	1700 / 520
F52-8T	2100 / 640
G33-7J	2650 / 800
G64-10W	3200 / 980

Recommended SU Motors:

Motor	Proj. Altitude (ft/m)
D21-4T	350 / 100
E15-7W	1050 / 320
E30-7T	1100 / 330
F20-7W*	1700 / 520
F23-7FJ*	1530 / 470
F25-9W	2200 / 670
F50-9T	2300 / 700
G35-7W*	2970 / 900
G38-7FJ*	2700 / 820
G40-10W	3300 / 1000
G80-10T	3150 / 950

*Econojet Motor



ARREAUX™

Our trademark rocket. Pronounced "aero," the Arreaux's payload section makes it perfect for lofting altimeters, accelerometers, and other experimental projects. With "G" powered flights approaching 3000 feet, this rocket cranks!

Specifications:

Length: 43"/109 cm
Diameter: 1.9"/4.7 cm
Weight (without motor):
12oz/340gms
Fins: 3
Product No. 89013

Recommended RMS Motors:

Motor	Proj. Altitude (ft/m)
D13-4W	300 / 90
D24-4T	400 / 120
D15-4T	300 / 90
E18-7W	900 / 270
E11-5J	700 / 210
E28-7T	950 / 290
F24-7W	1100 / 330
F12-5J	900 / 270
F39-6T	1350 / 410
E16-7W	850 / 260
E23-5T	750 / 230
F40-10W	2100 / 640
F22-7J	1600 / 480
F52-8T	2050 / 620
G33-7J	2550 / 770
G64-10W	3150 / 950

Recommended SU Motors:

Motor	Proj. Altitude (ft/m)
D21-4T	300 / 90
E15-7W	950 / 290
E30-7T	1050 / 320
F20-7W*	1600 / 480
F23-7FJ*	1440 / 440
F25-9W	2200 / 670
F50-9T	2150 / 660
G35-7W*	2880 / 870
G38-7FJ*	2600 / 790
G40-10W	3200 / 970
G80-10T	3100 / 940

*Econojet Motor



Projected Altitudes

For a given motor/rocket combination, the projected altitude shown will vary from rocket to rocket and flight to flight because of differences in launch site elevation, completed rocket weight, smoothness of finish, weather conditions and normal variation in motor performance. Projected altitudes are for a sea level launch site and without the rocket carrying any payload.



MIRAGE™

For those who want to fly a really big rocket, the Mirage is it! Lift-offs are impressively slow and realistic when this 7 foot monster roars off the pad on "G" power. Recovery is on two big nylon parachutes.

Specifications:

Length: 87"/220 cm
Diameter: 2.6"/6.7 cm
Weight (without motor): 31oz/880gms
Fins: 3
Product No. 89019

Recommended RMS Motors:

Motor	Proj. Altitude (ft/m)
F40-4W	650 / 200
F52-5T	650 / 200
G64-4W	1300 / 400

Recommended SU Motors:

Motor	Proj. Altitude (ft/m)
F50-4T	650 / 200
G35-4W*	1130 / 340
G38-4FJ*	1020 / 310
G40-4W	1250 / 380
G80-4T	1300 / 400

*Econojet Motor



TM

SUMO™

For those who love to see a short, fat rocket with slow lift offs, the Sumo is it! A big four inch diameter kit with impressive decals, the SUMO really stands out!

Specifications:

Length: 39"/99 cm
Diameter: 4.0"/10.1 cm
Weight (without motor): 32oz/907gms
Fins: 4
Product No. 89024

**LEVEL 1
READY!**

Recommended RMS Motors:

Motor	Proj. Altitude (ft/m)
G64-4W	800 / 240
H128W-S*	2000 / 600
H165R-S*	2000/600
H238T-S*	2000 / 600
H180W-M*	2600/790
H210R-M*	2600/790

Recommended SU Motors:

Motor	Proj. Altitude (ft/m)
G35-4W	650 / 200
G38-4FJ	650 / 200
G40-4W	800 / 240
G80-4T	800 / 240

*Easy Access RMS Motor



ASTROBEE D™

The AeroTech flagship. A painstakingly crafted scale model, the "D" is nearly 6 feet of breathtaking molded detail. All of AeroTech's trademark construction features combine with "G" power to make this kit a "must have" rocket experience.

Specifications:

Length: 68"/173 cm
Diameter: 2.6"/6.7 cm
Weight (without motor): 28oz/790gms
Fins: 4
Product No. 89015

Recommended RMS Motors:

Motor	Proj. Altitude (ft/m)
F40-4W	750 / 230
F52-5T	750 / 230
G64-4W	1350 / 410

Recommended SU Motors:

Motor	Proj. Altitude (ft/m)
F50-4T	750 / 230
G35-4W*	1210 / 365
G38-4FJ*	1090 / 330
G40-4W	1350 / 410
G80-4T	1400 / 430

*Econojet Motor



G-FORCE™

This kit stands over five feet tall! Featuring a big four inch diameter, the G-Force provides spectacular slow lift-offs when powered by AeroTech "G" motors.

Specifications:

Length: 60"/152cm
Diameter: 4"/10.1 cm
Weight (without motor): 32oz/907gms
Fins: 3
Product No. 89021

Recommended RMS Motors:

Motor	Proj. Altitude (ft/m)
G64-4W	800 / 240

Recommended SU Motors:

Motor	Proj. Altitude (ft/m)
G35-4W*	675 / 210
G38-4FJ*	610 / 190
G40-4W	750 / 230
G80-4T	800 / 240

*Econojet Motor





HV ARCASTM

This replica is 60% the size of the actual high-velocity Arcas sounding rocket and features precision molded fins, authentic decals, a data plate and detailed engineering blue-print.

Specifications:

Length: 56"/142 cm
Diameter: 2.6"/6.7 cm
Weight (without motor):
22oz/620gms
Fins: 4
Product No. 89012

Recommended RMS Motors:

Motor	Proj. Altitude (ft/m)
E28-4T	450 / 140
F24-4W	500 / 150
F39-6T	550 / 170
F40-4W	1100 / 330
F52-5T	1000 / 300
G33-5J	1300 / 400
G64-7W	1750 / 530

Recommended SU Motors:

Motor	Proj. Altitude (ft/m)
E30-4T	450 / 140
F20-4W*	1000 / 300
F23-4FJ*	900 / 270
F25-6W	1050 / 320
F50-6T	1150 / 350
G35-7W*	1660 / 500
G38-7FJ*	1500 / 450
G40-7W	1850 / 560
G80-7T	1800 / 550

*Econojet Motor



IQSY TOMAHAWK™

If you have never built a scale model before, the Tomahawk makes the perfect first project. Loaded with striking detail and E, F, and G power capable, this is one scale model that flies like a real sounding rocket.

Specifications:

Length: 41"/104 cm
Diameter: 1.9"/4.7 cm
Weight (without motor):
11oz/310gms
Fins: 4
Product No. 89014

Recommended RMS Motors:

Motor	Proj. Altitude (ft/m)
D24-4T	350 / 100
E18-7W	900 / 270
E11-5J	600 / 180
E28-7T	850 / 260
F24-7W	1100 / 330
F12-5J	800 / 240
F39-6T	1250 / 380
E16-7W	850 / 260
E23-5T	650 / 200
F40-10W	2100 / 640
F22-7J	1500 / 450
F52-8T	1950 / 590
G33-7J	2450 / 740
G64-10W	3150 / 950

Recommended SU Motors:

Motor	Proj. Altitude (ft/m)
D21-4T	300 / 90
E15-7W	800 / 240
E30-7T	850 / 260
F20-7W*	1450 / 440
F23-7FJ*	1300 / 400
F25-9W	1800 / 550
F50-9T	1950 / 590
G35-7W*	2475 / 745
G38-7FJ*	2230 / 680
G40-10W	2750 / 830
G80-10T	2750 / 830

*Econojet Motor



STRONG ARM™

Featuring molded plastic fins and strakes, a huge self-adhesive decal sheet, and the styling of the Navy's Standard ARM missile, the Strong Arm is as beautiful to look at as it is to fly.

Specifications:

Length: 44"/112 cm
Diameter: 2.6"/6.7 cm
Weight (without motor):
18oz/510gms
Fins: 4
Product No. 89017

Recommended RMS Motors:

Motor	Proj. Altitude (ft/m)
E18-4W	450 / 140
E28-4T	500 / 150
F24-4W	700 / 210
F39-6T	700 / 210
E16-4W	400 / 120
F40-7W	1150 / 350
F22-5J	850 / 260
F52-8T	1150 / 350
G33-5J	1450 / 440
G64-7W	1800 / 550

Recommended SU Motors:

Motor	Proj. Altitude (ft/m)
E15-4W	450 / 140
E30-4T	500 / 150
F20-4W*	750 / 230
F23-4FJ*	675 / 200
F25-6W	1100 / 330
F50-6T	1150 / 350
G35-7W*	1665 / 500
G38-7FJ*	1500 / 460
G40-7W	1850 / 560
G80-7T	1800 / 550

*Econojet Motor

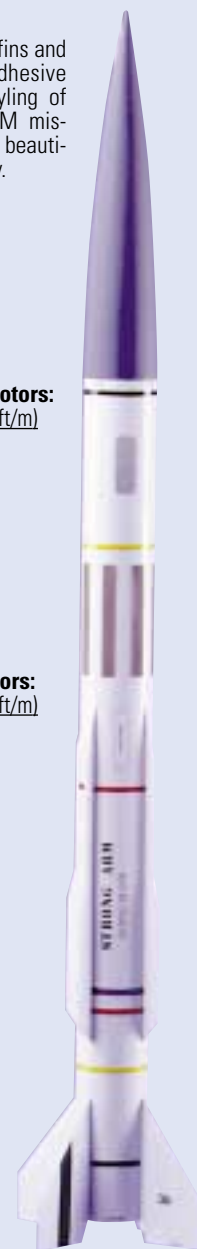



WART-HOG™

As tough and "stout" as its name-sake, the AeroTech Wart-Hog blends E, F, and G performance with the construction convenience of molded fins and self-adhesive decals to create a large rocket of a different breed.

Specifications:

Length: 37"/94 cm
Diameter: 2.6"/6.7 cm
Weight (without motor):
14oz/400gms
Fins: 4
Product No. 89018

Recommended RMS Motors:

Motor	Proj. Altitude (ft/m)
E18-4W	600 / 180
E11-3J	450 / 140
E28-4T	650 / 200
F24-4W	850 / 260
F12-3J	600 / 180
F39-6T	850 / 260
E16-4W	500 / 150
E23-5T	500 / 150
F40-7W	1350 / 410
F22-5J	1050 / 320
F52-8T	1300 / 400
G33-7J	1650 / 500
G64-7W	1900 / 580

Recommended SU Motors:

Motor	Proj. Altitude (ft/m)
E15-4W	650 / 200
E30-4T	650 / 200
F20-4W*	1000 / 300
F23-4FJ*	900 / 270
F25-6W	1300 / 400
F50-6T	1300 / 400
G35-7W*	1800 / 550
G38-7FJ*	1620 / 500
G40-7W	2000 / 600
G80-7T	1900 / 580

*Econojet Motor



CHEETAH™

Like its namesake, this rocket is simply fast! The Cheetah is also AeroTech's altitude champ, soaring to 3500 feet on "G" power. Our patented no-wadding ejection system and nylon parachute bring this cat back home flight after flight.

Specifications:

Length: 32"/81 cm
Diameter: 1.9"/4.7 cm
Weight (without motor):
10oz/280gms
Fins: 3
Product No. 89016

Recommended RMS Motors:

Motor	Proj. Altitude (ft/m)
D13-4W	400 / 120
D24-4T	500 / 150
D15-4T	400 / 120
E18-7W	1150 / 350
E11-5J	900 / 270
E28-7T	1150 / 350
F24-7W	1500 / 450
F12-5J	1200 / 360
F39-9T	1550 / 470
E16-7W	950 / 290
E23-8T	900 / 270
F40-10W	2300 / 700
F22-7J	1850 / 560
F52-8T	2200 / 670
G33-7J	2750 / 830
G64-10W	3200 / 970

Recommended SU Motors:

Motor	Proj. Altitude (ft/m)
D21-4T	400 / 120
E15-7W	1150 / 350
E30-7T	1150 / 350
F20-7W*	1800 / 550
F23-7FJ*	1620 / 500
F25-9W	2250 / 680
F50-9T	2200 / 670
G35-7W*	3000 / 910
G38-7FJ*	2700 / 820
G40-10W	3350 / 1020
G80-10T	3200 / 970

*Econojet Motor



BARRACUDA™

Sleek, slender and over 4 feet tall, the Barracuda is sure to impress everyone with its standout good looks and majestic flights. As with all our kits, the features include molded fins and nose cone, and a no-wadding ejection system!

Specifications:

Length: 56"/142 cm
Diameter: 1.9"/4.7 cm
Weight (without motor):
14oz/400gms
Fins: 3
Product No. 89020

Recommended RMS Motors:

Motor	Proj. Altitude (ft/m)
E18-4W	750 / 230
E11-3J	500 / 150
E28-4T	800 / 240
F24-7W	1100 / 330
F12-5J	700 / 210
F39-6T	1150 / 350
E16-4W	600 / 180
E23-5T	600 / 180
F40-7W	1900 / 580
F22-7J	1400 / 430
F52-8T	1850 / 560
G33-7J	2350 / 710
G64-10W	3000 / 910

Recommended SU Motors:

Motor	Proj. Altitude (ft/m)
E15-4W	800 / 240
E30-4T	800 / 240
F20-7W*	1350 / 410
F23-7FJ*	1220 / 370
F25-9W	1850 / 560
F50-9T	1900 / 580
G35-7W*	2745 / 835
G38-7FJ*	2470 / 750
G40-10W	3050 / 930
G80-10T	3000 / 910

*Econojet Motor



BUILDING COMPONENTS

Motor Mount/Fin-Lok™ Kits

Product	Part Number
Fin-Lok™ Kits Include: Motor Tube, Fin-Lok™ rings, motor hook, cooling mesh, screw eye, ejection gas baffle, screw eye, thrust ring, thrust ring flange, centering rings.	
29mm x 12" Motor Mount Tube Only	12912
29mm x 17-3/4" Motor Mount Tube Only	12918
1.9" / 3-fin Kit	21903
1.9" / 4-fin Kit	21904
2.6" / 3-fin Kit	22603
2.6" / 4-fin Kit	22604
4.0" / 3-fin Kit	22605
4.0" / 4-fin Kit	22606

Precision Airfoil Molded Fins

Product	Part Number
Precision airfoils molded from high impact white polystyrene. All have Fin-Lok fin tabs. Most fins can be used on either 1.9", 2.6" or 4.0" diameter tubes.	
Mustang/Arreaux style	11710
Initiator style	11711
Arcas/Wart-Hog style	11712
Tomahawk/Strong Arm style	11714
Astrobee D/Mirage/G-Force/Sumo style	11715
Cheetah style	11716
Barracuda style	11720

Body Tubes & Couplers

Product	Part Number
Strong and smooth. Choose from slotted and unslotted types. Slotted tubes come with launch lug alignment slots, too.	
1.9" Slot / 3-fin 22.75"	11924
1.9" Slot / 4-fin 22.75"	11923
1.9" Unslotted 22.75"	11926
1.9" Unslotted 12.00"	11912
1.9" Unslotted 9.00"	11909
1.9" Coupler 4"	11804
2.6" Coupler 6"	12606
2.6" Unslotted 15"	12615
2.6" Unslotted 19"	12619
2.6" Slot / 4-fin 24.00"	12623
2.6" Slot / 3-fin 24.00"	12624
2.6" Slot/ 3-fin 24.00" (Mirage Lower Tube)	12625
2.6" Unslotted 24"	12626
2.6" Launch Lug Slot 24.00" (Mirage Center Tube)	12627
2.6" Slot/ 4-fin 27.00" (Astrobee Lower Tube)	12628
2.6" Launch Lug Slot 27.00" (Astrobee Upper Tube)	12629
2.6" Tube sleeve 4"	12704
4.0" Coupler 6"	14008
4.0" Unslotted 19"	14019
4.0" Unslotted 23"	14033
4.0" Slot / 3-fin 23"	14023
4.0" Slot / 4-fin 23"	14040

Bulkhead Assemblies

Product	Part Number
Bulkhead Assemblies include: Coupler tube, bulkhead, and screw eye.	
1.9" Diameter body tubes	14819
2.6" Diameter body tubes	11614
4.0" Diameter body tubes	11615

Nose Cones

Product	Part Number
Blow molded with built-in shock cord attachment loop.	
1.9" 5:1 Ogive	11191
2.6" 5:1 Ogive	11261
4.0" 4:1 Ogive 5 oz. (Color: White)	11401
4.0" 4:1 Ogive 9 oz. (Color: Grey)	11405

Recovery Systems

Product	Part Number
Preassembled fabric parachutes with six shroud lines. All parachutes are made in the U.S.A.	
16" Fabric parachute	13016
22" Fabric parachute	13022
30" Fabric parachute	13030
42" Fabric parachute	13042
3/8" x 6' Shock cord	17386
3/8" x 8' Shock cord	17388
5/8" x 18' Shock cord	17201

Motor Accessories

Product	Part Number
Motor Hook	19001
"E" adapter, "F" spacer	14005
RMS Aft Closure Wrench	91295

Decals & Scale Details

Product	Part Number
Mustang™ decal sheet	18010
Initiator™ decal sheet	18011
Arcas decal sheet	18012
Arreaux™ decal sheet	18013
Tomahawk decal sheet	18014
Astrobee D decal sheet	18015
Cheetah™ decal sheet	18016
Strong Arm™ decal sheet	18017
Wart-Hog™ decal sheet	18018
Mirage™ decal sheet	18019
Barracuda™ decal sheet	18020
G-Force™ decal sheet	18021
Sumo™ decal sheet	18023
Arcas data plate	18912

RMS Aft closure wrench part # 91295



AEROWEAR

You too can wear official AeroTech clothing known as AeroWear. Choose from a variety of clothing items including an embroidered base ball cap, embroidered polo shirt, or exclusive AeroWear T-shirt. If you fly AeroTech, wear one of these items to show it!



AeroTech Hat: Made of thick black cotton, this hat features gold trim and an embroidered AeroTech logo.
Product No.: 94400



AeroTech Polo Shirt: Fabricated of a thick cotton-poly blend, the shirt features an embroidered AeroTech logo and distinctive yellow & black trim.
Product No.: 94520 (Medium), 94525 (Large), 94530 (XL) 94535 (XXL)



AeroTech 'AeroWear' T-shirt: Made of 100% cotton, the AeroTech T-shirt is perfect for any rocket launch.
Product No.: 94500 (Medium), 94505 (Large), 94510 (XL)



AEROWEAR

COMPOSITE PROPELLANTS

AeroTech Composite Rocket Motors are the most technically advanced hobby motors in the world. These motors use the same solid propellant as America's space boosters. Pound for pound, this propellant delivers nearly three times the power of black powder model rocket motors, allowing you to fly larger rockets, heavier payloads and achieve higher altitudes than ever before. AeroTech Composite Rocket Motors come in five propellant formulations for both reloadable and single use motors. Create your own special effects by choosing the performance, tracking and sound characteristics you desire.

MOTOR DESIGNATIONS

Each AEROTECH composite hobby rocket motor or reload kit has a designation which provides important information about performance. The designation is read as follows:

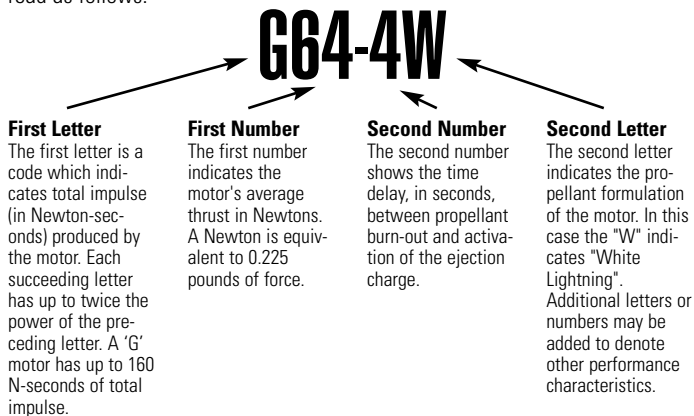

FIVE PROPELLANT TYPES

White Lightning™ (W)

A brilliant white flame, dense bright white exhaust and a throaty roar are the hallmarks of this popular propellant. Easy to track. Exciting to watch! White Lightning looks and sounds like actual sounding rockets and launch vehicles. Special effects professionals and aerospace companies specify the AeroTech White Lightning propellant to achieve realistic simulation.

Blue Thunder™ (T)

Produces a bright violet-blue flame with a minimum of exhaust smoke. These motors provide a higher level of thrust than White Lightning or Black Jack motors of the same total impulse. Blue Thunder is the perfect propellant for the greatest lift-off acceleration.

Black Jack™ (J) and Black Max™ (FJ)

Provides the high visibility tracking of dense black exhaust. In addition to a distinctive lift off roar, Black Jack motors give your models lower acceleration and longer powered flight than White Lightning or Blue Thunder motors of the same total impulse. Black Max provides slightly higher acceleration than White Lightning Propellant and will be available in RMS motors beginning 2001.

New for 2001: Redline™ (R)

Distinctly different from its propellant relatives, Redline provides unique liftoff characteristics for larger airframes and performance oriented flyers. The proprietary AeroTech formulation provides Redline with its signature scarlet flame.



Pete Lardizabal with his upscale Mars Lander powered by an H180W motor.



SINGLE USE MOTORS

AeroTech established its position as the leader in hobby rocket motor technology with its single-use composite motors. Hobby rocketry has come to depend on AeroTech motors for sport and competition flying.

AeroTech's single-use composite model rocket motors are now offered in over 60 different combinations of physical size, power, burn time, propellant type and delay length. All rocket motors are certified by the National Association of Rocketry and the Tripoli Rocketry Association.

In 1997, AeroTech introduced the "Econojet" line of single-use motors. AeroTech combined features of performance, design and packaging in the Econojets to create a line of motors that could be sold at a price point midway between its traditional single-use motors and RMS reload kits.

ECONOJET MOTORS

Motor	Diameter	Case Length	Total Impulse	Prop. Wt.	Motor Wt.	Delay Times
F20W (2-pak)	1.13" (29mm)	2.88"	65 N-sec	30 g	76 g	4, 7
F23FJ (2-pak)	1.13" (29mm)	2.88"	56 N-sec	32 g	78 g	4, 7
G35W (2-pak)	1.13" (29mm)	3.88"	104 N-sec	50 g	100 g	4, 7
G38FJ (2-pak)	1.13" (29mm)	3.88"	94 N-sec	55 g	105 g	4, 7

HOBBY LINE SINGLE USE MOTORS

Motor	Diameter	Case Length	Total Impulse	Prop. Wt.	Motor Wt.	Delay Times
D21T	.70" (18mm)	2.75"	20 N-sec	9.6 g	23 g	4, 7
E15W	.94" (24mm)	2.75"	40 N-sec	20.1 g	48 g	4, 7
E30T	.94" (24mm)	2.75"	40 N-sec	19.3 g	47 g	4, 7
F25W	1.13" (29mm)	3.88"	80 N-sec	41.5 g	89 g	4, 6, 9
F50T	1.13" (29mm)	3.88"	80 N-sec	38.3 g	83 g	4, 6, 9
G40W	1.13" (29mm)	4.88"	120 N-sec	62.4 g	125 g	4, 7, 10
G80T	1.13" (29mm)	4.88"	120 N-sec	57.4 g	120 g	4, 7, 10

HIGH POWER SINGLE USE MOTORS

Motor	Diameter	Case Length	Total Impulse	Prop. Wt.	Motor Wt.	Delay Times
H55W*	1.13" (29mm)	7.50"	170 N-sec	92.8 g	182 g	6, 10, 14
H70W*	1.13" (29mm)	9.06"	200 N-sec	102.0 g	221 g	6, 10, 14
H124J*	1.13" (29mm)	9.88"	250 N-sec	164.7 g	250 g	6, 10, 14
H125W*	1.13" (29mm)	13.00"	320 N-sec	150.7 g	353 g	6, 10, 14
H45W*	1.5" (38mm)	6.56"	320 N-sec	186.1 g	307 g	10, 15
I132W*	1.5" (38mm)	11.88"	640 N-sec	363.3 g	596 g	10, 15
I65PW*	2.125" (54mm)	7.75"	640 N-sec	378.0 g	625 g	plugged
J125PW*	2.125" (54mm)	13.12"	1280 N-sec	720.5 g	1100 g	plugged
K250PW*	2.125" (54mm)	25.13"	2560 N-sec	1397.0 g	2370 g	plugged
K1050PW*	2.125" (54mm)	25.13"	2560 N-sec	1365.3 g	2250 g	plugged

NON-STANDARD HOBBY LINE SINGLE USE MOTORS

Motor	Diameter	Case Length	Total Impulse	Prop. Wt.	Motor Wt.	Delay Times
F32W*	.94" (24mm)	4.88"	80 N-sec	37.7 g	72.2 g	5, 10, 15
F72T*	.94" (24mm)	4.88"	80 N-sec	36.8 g	73.1 g	5, 10, 15
F101T*	.94" (24mm)	4.88"	80 N-sec	35.5 g	71.8 g	5, 10, 15
G55W*	.94" (24mm)	6.94"	125 N-sec	62.5 g	103.7 g	5, 10, 15
G25W*	1.13" (29mm)	4.88"	120 N-sec	62.5 g	105.0 g	5, 10, 15
G125T*	1.13" (29mm)	4.88"	125 N-sec	60.5 g	105.0 g	5, 10, 15

*Dealer Direct Items

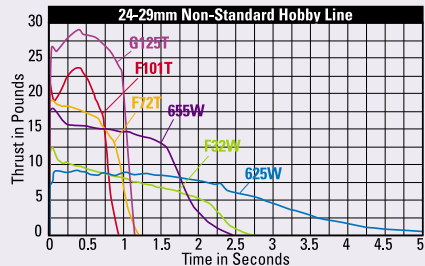
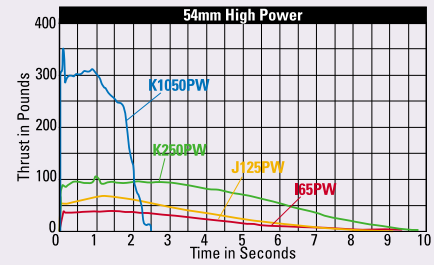
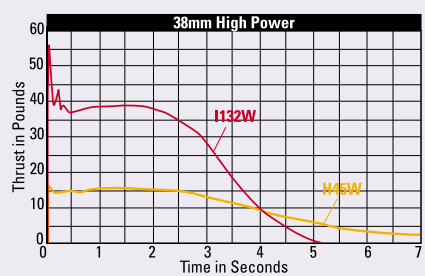
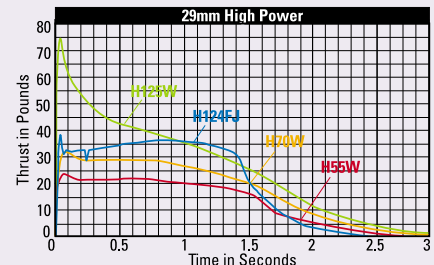
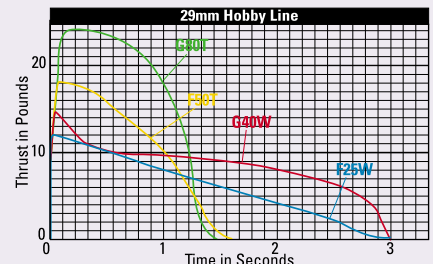
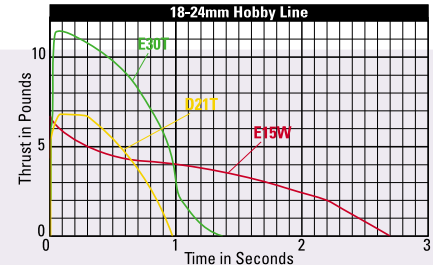
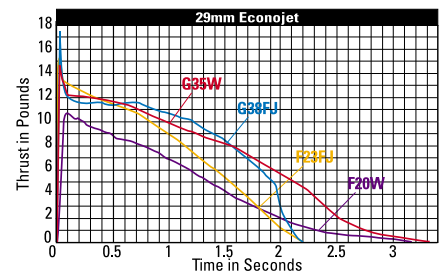

Typical Hobby Line Single Use Motors

RELOADABLE MOTOR SYSTEM™ (RMS™)

Now you can enjoy high power rocketry at greatly reduced cost, improved reliability and enhanced flexibility with the RMS Reloadable Motor System from AeroTech! Since 1990, when AeroTech revolutionized the hobby rocket industry with the invention and introduction of the RMS, rocket enthusiasts have been enjoying the cost and performance advantages of AeroTech's line of precision machined reloadable aluminum rocket motors and reload kits.

With the availability of a growing line of Blue Thunder, White Lightning, Redline, and Black Jack propellant reloading kits, RMS high power rocket enthusiasts not only have tremendous versatility at their fingertips but also the advantage of flight costs significantly lower than that available from single-use high power motors!

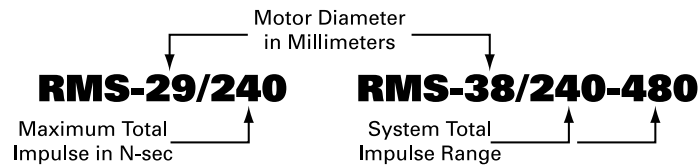

Hobby Line RMS

AeroTech introduced the hobby line RMS in 1991. There are AeroTech RMS motors to fit just about all rocket kits designed for black powder and composite motors. No modification to the rocket is necessary. As is always the case, you should perform a stability and strength check to see that the power and weight of a motor is appropriate for the rocket the motor is to be used in. An investment in RMS give you a position in a wide range of reload kits. Each RMS motor offers flexible power options.

RMS-Plus™ Delay Sealing System for 29 & 38mm High Power RMS

The new AeroTech RMS-Plus delay sealing system provides for more precise delay times, reduced chances of forward closure blow-by, easier cleanup, and more! This new design seals radially rather than axially as in previous RMS reload kits. Motors may now be left assembled indefinitely, and there is no need to remove the delay charge assembly if the closures are loosened. All RMS-Plus reload kits come with new improved illustrated instructions. Best of all, no new hardware purchase is necessary—RMS-Plus technology is completely compatible with existing AeroTech RMS motors!



Easy Access™ High Power RMS

In 1995, AeroTech took steps to make your involvement in high power even easier through the creation of the Easy Access and Restricted Access high power rocket motor product lines. With Easy Access, AeroTech has made it possible for appropriately certified rocket enthusiasts to see at a glance which high power reload kits and related products may be obtained and flown by certified users without special purchase and storage requirements. Easy Access encompasses the entire AeroTech 29mm & 38mm high power reload kit line. In 1996, AeroTech introduced a number of new Easy Access reload kits, including the 29mm H220T, the 38mm I300T, I195J, I435T and the 38/720 J350W. 1998 saw the release of the new "King of Grunt", the 9 grain 38mm J570W. In 1999 we extended the power of 29mm motor line for the first time since the inception of the RMS with the 29/360 motor and the six-grain I200W reload kit!

Restricted Access™ High Power RMS

Restricted Access, on the other hand, allows AeroTech to clearly identify for the high power rocket enthusiast, those high power reload kits and accessories that are currently subject to more stringent federal laws where their purchase, storage and transportation are concerned. If you possess a Bureau of Alcohol, Tobacco and Firearms (BATF) Low Explosives User Permit, keep in mind that AeroTech continues to lead the industry in supplying "J" through "N" class reload kits. This includes AeroTech's hugely popular "Long Burn 54's", the J90W, J135W and K185W reloads. 1996 saw the granting of DOT-E 10996, a shipping exemption which permits the transportation of all Restricted Access reload kits by UPS® ground service. Recent product releases in the Restricted Access line include the 54/2560 motor and K700W reload, the 75mm motor series and the only Tripoli certified "N" motor available, the 98/15360 N2000W. 1999 saw the introduction of the awesome Blue Thunder reload kits for AeroTech's popular 98mm motors.



FirstFire™ & FirstFire Jr.™ Igniters

New for 2000, these igniters are now included with all AeroTech RMS Easy Access high power reload kits. FirstFire igniters provide an easy-to-use two lead system and a high temperature pyrogen mixture to light your motors reliably every time. FirstFire igniters are also sold separately in three packs. FirstFire: H & above. FirstFire Jr.: F & G only.

Product No.: 89894 (FirstFire)
Product No.: 89895 (FirstFire Jr.)

HOBBY LINE RMS HARDWARE DATA

RMS-18 Motor Hardware Data

Hardware	Outer Diameter	Length (w/o closures)	Weight
RMS-18/20	.698" (18mm)	2.69"	11.8 g

RMS-24 Motor Hardware Data

Hardware	Outer Diameter	Length (w/o closures)	Weight
RMS-24/40	.938" (24mm)	2.69"	19.7 g

RMS-29 Motor Hardware Data

Hardware	Outer Diameter	Length (w/o closures)	Weight
RMS-29/40-120	1.125" (29mm)	4.88"	58g

RMS/RC-24 Motor Hardware Data

Hardware	Outer Diameter	Length (w/o closures)	Weight
RMS-24/20-40	.938" (24mm)	2.75"	20 g

RMS/RC-32 Motor Hardware Data

Hardware	Outer Diameter	Length (w/o closures)	Weight
RMS-32/60-100	1.250" (32mm)	4.0"	56.9 g

Note: The diameter of the motor is measured from the outside of the motor tube to the opposite side. Length is measured without inclusion of the forward or aft closures.

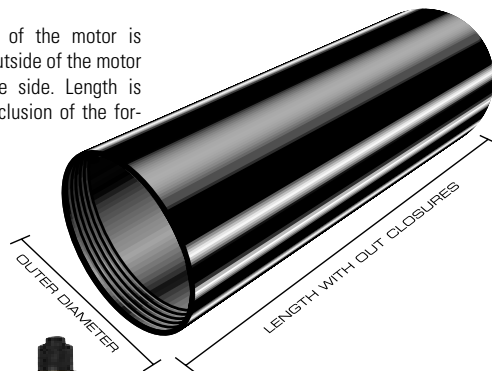

William Walby holding a 98mm RMS Motor.



HIGH POWER RMS HARDWARE DATA

RMS-29 Motor Hardware Data

Hardware	Outer Diameter	Length (w/o closures)	Weight	Options
RMS-29/60	1.125" (29mm)	3.902"	57.5 g	Plugged forward closure
RMS-29/100	1.125" (29mm)	4.902"	61.6 g	Plugged forward closure
RMS-29/180	1.125" (29mm)	7.660"	84.7 g	Plugged forward closure
RMS-29/240	1.125" (29mm)	9.420"	105.3 g	Plugged forward closure
RMS-29/360	1.125" (29mm)	13.10"	138 g	Plugged forward closure

RMS-38 Motor Hardware Data

Hardware	Outer Diameter	Length (w/o closures)	Weight	Options
RMS-38/240	1.500" (38mm)	6.073"	125.5 g	Plugged forward closure
RMS-38/360	1.500" (38mm)	7.948"	147.4 g	Plugged forward closure
RMS-38/480	1.500" (38mm)	9.823"	168.5 g	Plugged forward closure
RMS-38/600	1.500" (38mm)	11.698"	190.4 g	Plugged forward closure
RMS-38/720	1.500" (38mm)	13.573"	212.3 g	Plugged forward closure
RMS-38/1080	1.500" (38mm)	19.2"	278 g	Plugged forward closure

RMS-54 Motor Hardware Data

Hardware	Outer Diameter	Length (w/o closures)	Weight	Options
RMS-54/852	2.125" (54mm)	9.489"	278.1 g	Plugged & ext fwd closure
RMS-54/1280	2.125" (54mm)	12.817"	338.2 g	Plugged & ext fwd closure
RMS-54/1706	2.125" (54mm)	16.146"	398.6 g	Plugged & ext fwd closure
RMS-54/2560	2.125" (54mm)	22.8"	519 g	Plugged & ext fwd closure

RMS-75 Motor Hardware Data

Hardware	Outer Diameter	Length (w/o closures)	Weight	Options
RMS-75/2560	2.965" (75mm)	15.58"	956 g	none
RMS-75/3840	2.965" (75mm)	20.89"	1182 g	none
RMS-75/5120	2.965" (75mm)	26.20"	1408 g	none
RMS-75/6400	2.965" (75mm)	31.52"	1684 g	none

RMS-98 Motor Hardware Data

Hardware	Outer Diameter	Length (w/o closures)	Weight	Options
RMS-98/2560	3.875" (98mm)	11.38"	1140 g	none
RMS-98/5120	3.875" (98mm)	17.45"	1530 g	none
RMS-98/7680	3.875" (98mm)	23.51"	1926 g	none
RMS-98/10240	3.875" (98mm)	29.57"	2367 g	none
RMS-98/15360	3.875" (98mm)	41.7"	3204 g	none

HARDWARE SYSTEMS

29/60-100 system

Includes two casings (29/60 & 29/100), one aft and one forward closure

29/180-240 system

Includes two casings (29/180 & 29/240), one aft and one forward closure and one forward seal disc

38/240-480 system

Includes three casings (38/240, 38/360 & 38/480), one aft and one forward closure and one forward seal disc

54/852-1706 system

Includes three casings (54/852, 54/1280 & 54/1706), one aft and one forward closure

75/2560-6400 system

Includes four casings (75/2560, 75/3840, 75/5120 & 75/6400), one aft and one plugged forward closure

98/2560-10240 system

Includes four casings (98/2560, 98/5120, 98/7680 & 98/10240), one aft and one plugged forward closure



www.aerotech-rocketry.com

HOBBY LINE RMS MOTORS

RMS-18 Reload Kit Data

Hardware	Reload	Total Impulse	Prop. Wt.	Loaded Wt.	Delay Times
RMS-18/20	D13W (3 pak)	20 N-sec	9.8 g	33 g	4, 7, 10
RMS-18/20	D24T (3 pak)	20 N-sec	8.7 g	31 g	4, 7, 10

Ejection charge included with all 18mm reload kits.

RMS-24 Reload Kit Data

Hardware	Reload	Total Impulse	Prop. Wt.	Loaded Wt.	Delay Times
RMS-24/40	D9W (3 pak)	20 N-sec	10.1 g	45 g	4, 7
RMS-24/40	D15T (3 pak)	20 N-sec	8.9 g	44 g	4, 7
RMS-24/40	E11J (3 pak)	35 N-sec	25 g	61 g	3
RMS-24/40	E18W (3 pak)	40 N-sec	20.7 g	57 g	4, 7
RMS-24/40	E28T (3 pak)	40 N-sec	18.4 g	55 g	4, 7
RMS-24/40	F12J (3 pak)	43 N-sec	30.3 g	67 g	3, 5
RMS-24/40	F24W (3 pak)	50 N-sec	25.3 g	62 g	4, 7
RMS-24/40	F39T (3 pak)	50 N-sec	22.7 g	59 g	6, 9

Ejection charge included with all 24mm reload kits.

RMS-29 Reload Kit Data

Hardware	Reload	Total Impulse	Prop. Wt.	Loaded Wt.	Delay Times
RMS-29/40-120	E16W	40 N-sec	19 g	107 g	4, 7
RMS-29/40-120	E23T	40 N-sec	17.4 g	104 g	5, 8
RMS-29/40-120	F22J	65 N-sec	46.3 g	133 g	5, 7
RMS-29/40-120	F40W	80 N-sec	40 g	126 g	4, 7, 10
RMS-29/40-120	F52T	80 N-sec	36.6 g	123 g	5, 8, 11
RMS-29/40-120	G33J	100 N-sec	72.2 g	159 g	5, 7
RMS-29/40-120	G64W	120 N-sec	62.5 g	151 g	4, 7, 10

Ejection charge included with all 29mm reload kits.

RMS-24 R/C Rocket Glider Reload Kit Data

Hardware	Reload	Total Impulse	Prop. Wt.	Loaded Wt.	Delay Times
RMS-24/20-40	D7-RCT (3 pak)	20 N-sec	10.5 g	41.3 g	plugged
RMS-24/20-40	E7-RCT (3 pak)	30 N-sec	17.1 g	46.4 g	plugged
RMS-24/20-40	E6-RCT (3 pak)	40 N-sec	21.5 g	52 g	plugged
RMS-24/20-40	E12-RCJ (3 pak)	36 N-sec	28.3 g	58.8 g	plugged

RMS-32 R/C Rocket Glider Reload Kit Data

Hardware	Reload	Total Impulse	Prop. Wt.	Loaded Wt.	Delay Times
RMS-32/60-100	F13-RCT (2 pak)	60 N-sec	31.2 g	105 g	plugged
RMS-32/60-100	F16-RCJ (2 pak)	80 N-sec	57.1 g	137 g	plugged
RMS-32/60-100	F23-RCW-SK (2 pak)	70 N-sec	35.2 g	127 g	plugged
RMS-32/60-100	G12-RCT (2 pak)	100 N-sec	51.1 g	126 g	plugged

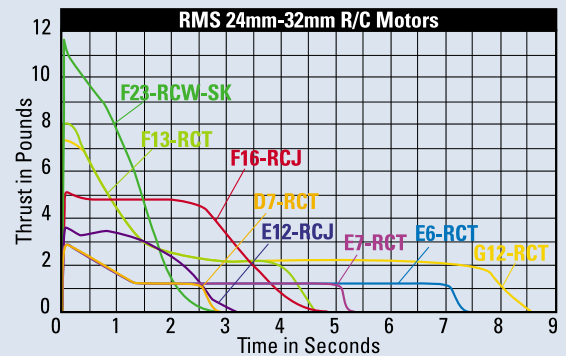
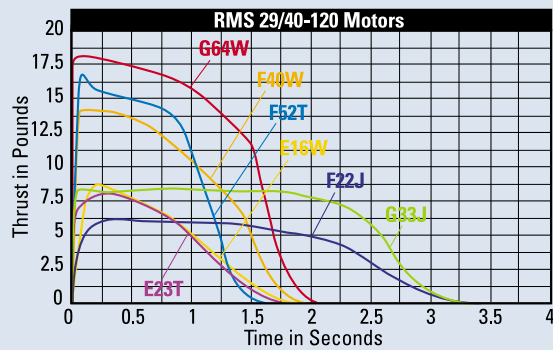
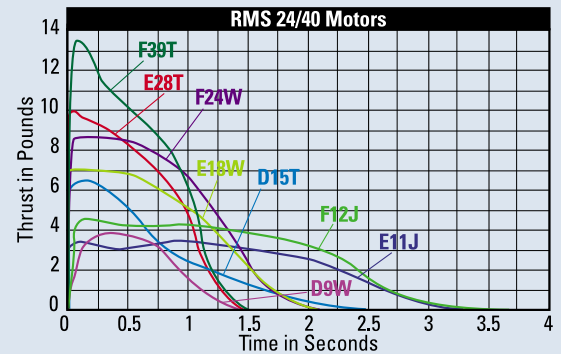
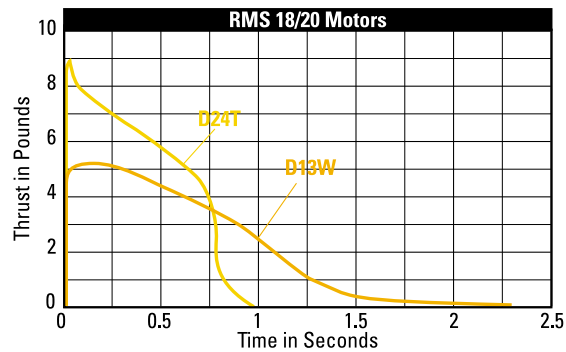

PROFESSIONAL MOTOR DESIGN

AeroTech's parent company, Industrial Solid Propulsion, Inc. (ISP), designs and manufactures rocket motors for research, aviation and space. AeroTech motors are designed by the same people who design motors for ISP.

Static test firing of an eight foot long ISP motor destined for space application.

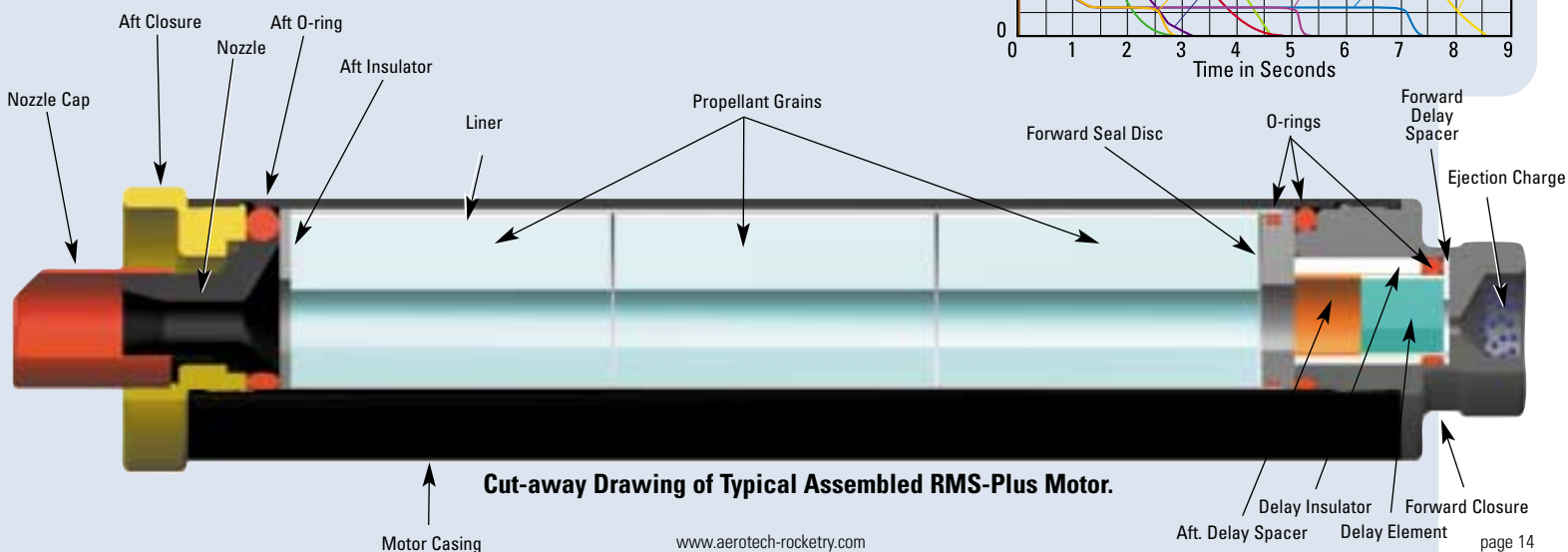

EASY ACCESS RMS MOTORS

RMS-29 Reload Kit Data

Hardware	Reload	Total Impulse	Prop. Wt.	Loaded Wt.	Delay Times
RMS-29/60	F37W	50 N-sec	28.2 g	112.2 g	S, M, L
RMS-29/60	F62T	50 N-sec	25.0 g	109.0 g	S, M, L
RMS-29/100	G54W	90 N-sec	46.0 g	140.8 g	S, M, L
RMS-29/100	G104T	90 N-sec	40.8 g	135.6 g	S, M, L
RMS-29/180	G75J	155 N-sec	105.6 g	227.9 g	S, M
RMS-29/180	H128W	175 N-sec	92.2 g	214.5 g	S, M, L
RMS-29/180	H238T	175 N-sec	79.8 g	202.1 g	S, M, L
RMS-29/240	H97J	200 N-sec	140.9 g	281.5 g	S, M
RMS-29/240	H180W	230 N-sec	123.0 g	263.6 g	S, M, L
RMS-29/240	H220T*	220 N-sec	106.4 g	238.6 g	S, M, L
RMS-29/360	I200W*	330 N-sec	175 g	364 g	S, M, L

Ejection charge included with all 29mm reload kits.

*29mm H220T & I200W reload kits must be used in conjunction with the 29mm forward seal disc.

RMS-38 Reload Kit Data

Hardware	Reload	Total Impulse	Prop. Wt.	Loaded Wt.	Delay Times
RMS-38/240	H73J	180 N-sec	125.0 g	293.3 g	S, M
RMS-38/240	H123W	230 N-sec	125.0 g	293.3 g	S, M, L
RMS-38/240	H242T	230 N-sec	110.8 g	279.1 g	S, M, L
RMS-38/360	H112J	280 N-sec	187.5 g	384.8 g	S, M
RMS-38/360	I161W	350 N-sec	187.5 g	384.8 g	S, M, L
RMS-38/360	I357T	350 N-sec	166.2 g	363.5 g	S, M, L
RMS-38/480	I154J*	360 N-sec	250.0 g	476.3 g	S, M
RMS-38/480	I211W*	460 N-sec	250.0 g	476.3 g	S, M, L
RMS-38/480	I300T*	440 N-sec	221.6 g	440.5 g	S, M, L
RMS-38/600	I195J*	478 N-sec	312.5 g	582.4 g	S, M
RMS-38/600	I284W*	590 N-sec	312.5 g	567.8 g	S, M, L
RMS-38/600	I435T*	600 N-sec	277.0 g	526.9 g	S, M, L
RMS-38/720	J350W*	700 N-sec	375.0 g	665.0 g	S, M, L
RMS-38/1080	J570W*	1060 N-sec	527.0 g	908.0 g	S, M, L

Ejection charge included with 38/240-360 reload kits only.

*38/480-38/1080 reload kits must be used in conjunction with the 38mm forward seal disc.

Notes:

- Total impulse shown is optimum
- Short=Approx. 6 sec.;
- Medium=Approx. 10 sec.;
- Long=Approx. 14 sec.;

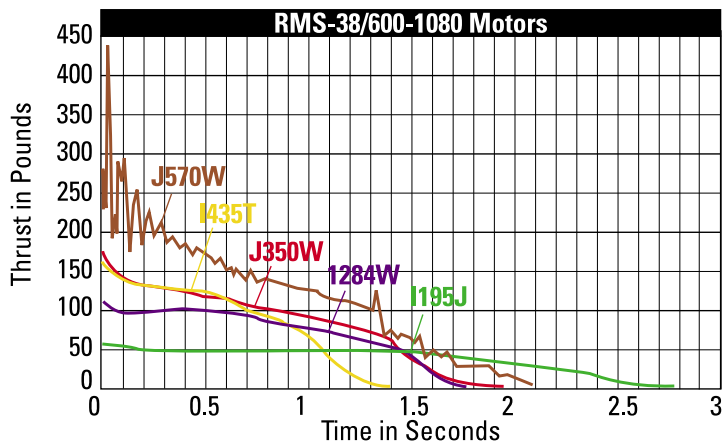
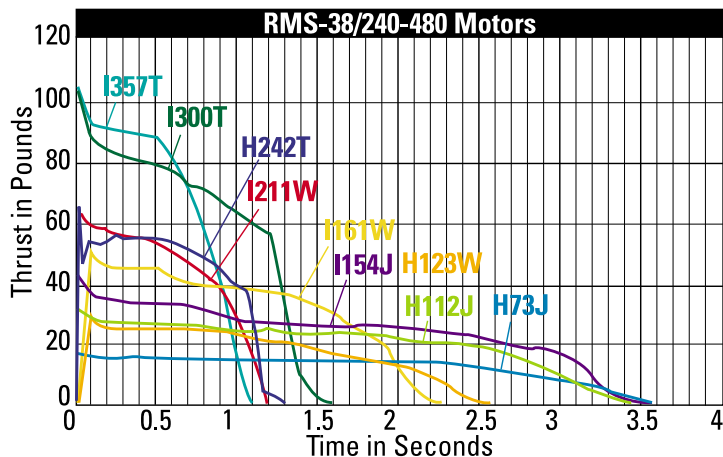
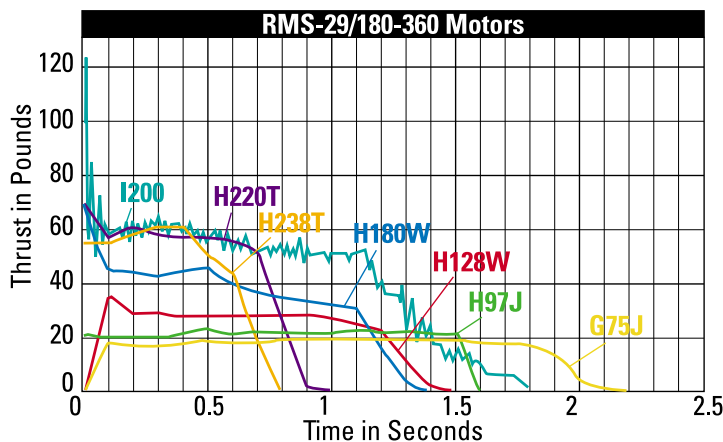
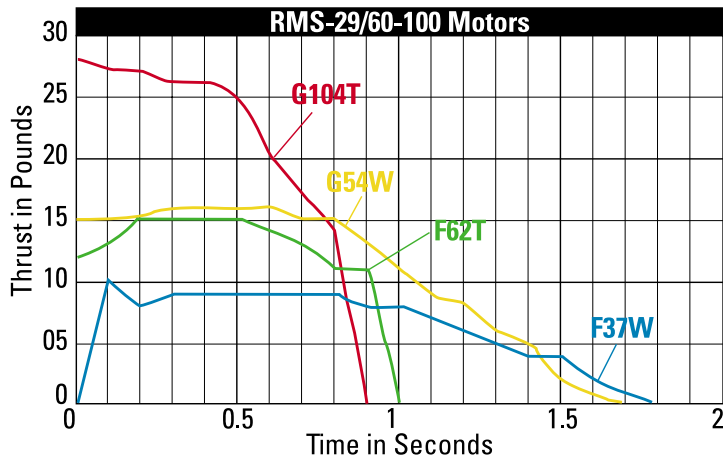

RESTRICTED ACCESS RMS MOTORS

RMS-54 Reload Kit Data

Hardware	Reload	Total Impulse	Prop. Wt.	Loaded Wt.	Delay Times
RMS-54/852	J90W*	770 N-sec	391.4 g	834.1 g	S, M, L
RMS-54/852	J180T	800 N-sec	398.2 g	840.9 g	S, M, L
RMS-54/852	J275W	850 N-sec	440.2 g	882.9 g	S, M, L, X
RMS-54/852	J460T	850 N-sec	390.2 g	832.9 g	S, M, L, X
RMS-54/1280	J135W*	1200 N-sec	587.1 g	1125.7 g	S, M, L
RMS-54/1280	J415W	1280 N-sec	660.3 g	1198.9 g	S, M, L, X
RMS-54/1280	J800T	1280 N-sec	595.3 g	1133.9 g	S, M, L, X
RMS-54/1706	K185W*	1500 N-sec	782.8 g	1417.5 g	S, M, L
RMS-54/1706	K550W	1700 N-sec	880.4 g	1515.1 g	S, M, L, X
RMS-54/1706	K1100T	1500 N-sec	733.3 g	1368.0 g	S, M, L, X
RMS-54/2560	K700W**	2400 N-sec	1232 g	2059 g	plugged

Ejection charge not included with 54mm reload kits.

*54mm J90W, J135W and K185W must be used with extended forward closure.

**Plugged reload kits do not utilize a motor actuated ejection charge. Plugged motors must be used in conjunction with a timer, altimeter or radio-activated recovery system.

RMS-75 Reload Kit Data

Hardware	Reload	Total Impulse	Prop. Wt.	Loaded Wt.	Delay Times
RMS-75/2560	K560W**	2560 N-sec	1341 g	2774 g	plugged
RMS-75/3840	L850W**	3840 N-sec	2011 g	3741 g	plugged
RMS-75/5120	L1120W**	5120 N-sec	2681 g	4708 g	plugged
RMS-75/6400	M1315W**	6400 N-sec	3351 g	5675 g	plugged

Ejection charge not included with 75mm reload kits.

**Plugged reload kits do not utilize a motor actuated ejection charge. Plugged motors must be used in conjunction with a timer, altimeter or radio-activated recovery system.

RMS-98 Reload Kit Data

Hardware	Reload	Total Impulse	Prop. Wt.	Loaded Wt.	Delay Times
RMS-98/2560	K458W**	2560 N-sec	1330.0 g	3106.2 g	plugged
RMS-98/2560	K650T**	2560 N-sec	1176 g	2957 g	plugged
RMS-98/5120	L952W**	5120 N-sec	2660 g	5027 g	plugged
RMS-98/5120	L1500T**	5120 N-sec	2351 g	4728 g	plugged
RMS-98/7680	M1419W**	7680 N-sec	3990.0 g	6931 g	plugged
RMS-98/7680	M2400T**	7680 N-sec	3527 g	6483 g	plugged
RMS-98/10240	M1939W**	10240 N-sec	5320.0 g	8844.5 g	plugged
RMS-98/10240	M2500T**	10240 N-sec	4572 g	8117 g	plugged
RMS-98/15360	N2000W**	14000 N-sec	7676.0 g	12412.0 g	plugged

Ejection charge not included with 98mm reload kits.

**Plugged reload kits do not utilize a motor actuated ejection charge. Plugged motors must be used in conjunction with a timer, altimeter or radio-activated recovery system.

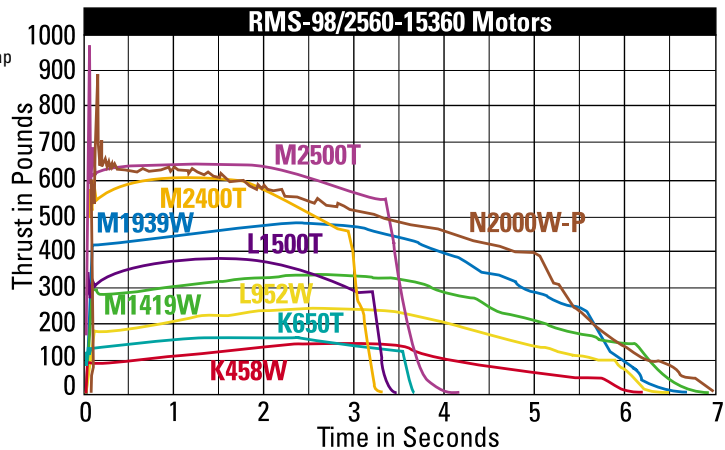
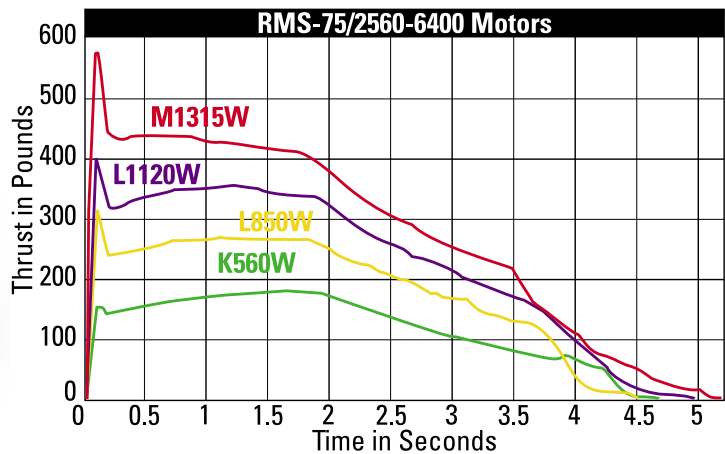
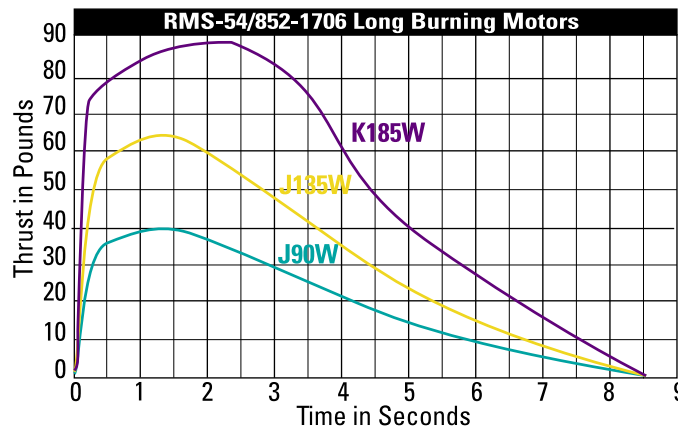
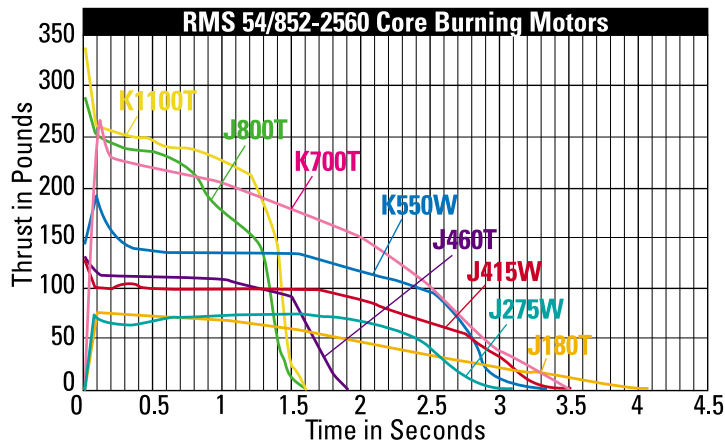

- Notes:**
- Total impulse shown is optimum
 - Short=Approx. 6 sec.;
 - Medium=Approx. 10 sec.;
 - Long=Approx. 14 sec.;
 - X-Long=Approx. 18 sec.

Contents of a Typical 38mm RMS Reload Kit

GETTING STARTED IN ROCKETRY

Hobby Rocket Categories

Model Rocketry

As children, many of us launched model rockets. Today, these rockets are made by Estes and Quest. Estes and Quest rockets are available in most hobby shops. These rockets use black powder motors up to "D" (20 N-sec) size. Each succeeding letter denotes up to twice the impulse of the smaller letter; a "C" motor is up to twice as powerful as a "B" motor. These rockets usually weigh a few ounces and fly less than 2000 feet high, which allows them to be flown in any open space without special permission. Model rockets are usually simple to build and are quite safe. Motors are relatively cheap, costing only a few dollars apiece.

Mid-Power Rocketry

Beyond model rocketry is what many call "mid-power rocketry." Rockets in this category typically use composite propellant motors in the "E" through "G" sizes. The largest manufacturer of mid-power kits and motors is AeroTech. Mid-power rockets also generally weigh under a pound, but can fly much higher than model rockets. Rockets which contain over 4 ounces of propellant or weigh over 1 pound require Federal Aviation Administration (FAA) notification 24 to 48 hours in advance. Mid-power rockets are not necessarily more difficult to build than model rockets. Composite propellant rocket motors are more expensive than black powder motors (\$4-\$15 per flight), but usually less per unit of power.

High-Power Rocketry

The largest rockets built with commercially manufactured motors and sanctioned by national organizations are classified as "High-Power Rockets." Motors used in this class range from "H" through "O" in size. The largest manufacturers of high-power kits are LOC/Precision and Public Missiles, Ltd., although there are other companies making these kits. These rockets generally weigh from a few pounds up to a hundred pounds or more and can fly up to 25,000 feet high or more. Some high-power rocket motors currently require federal licensing and approvals to purchase and fly and can only be flown at organized club launches held in unpopulated areas of large open space. High-power rockets are the most challenging rockets which fly on pre-manufactured motors and appeal to those who like large vehicles and enjoy the impressive flights with the larger, more powerful and more expensive (\$20-\$1,000 per flight) motors. More advanced materials and techniques are required for high-power rockets because of the dramatically increased stresses encountered in flight.

Experimental Rocketry

Those who build their own rocket motors rather than using commercially manufactured motors engage in a hobby rocket category known as "Experimental Rocketry." Motors can be any size, though generally they tend to be in the smaller high-power range. In some ways, amateur rocketry is less regulated than high-power rocketry, although the FAA requirements are the same. Making your own motors can be dangerous and should not be undertaken lightly. Amateur rocketry is appealing to people who either want to do everything themselves or enjoy the process of developing and making their own motors. It should be noted, however, that making your own motors is rarely a money-saving proposition.

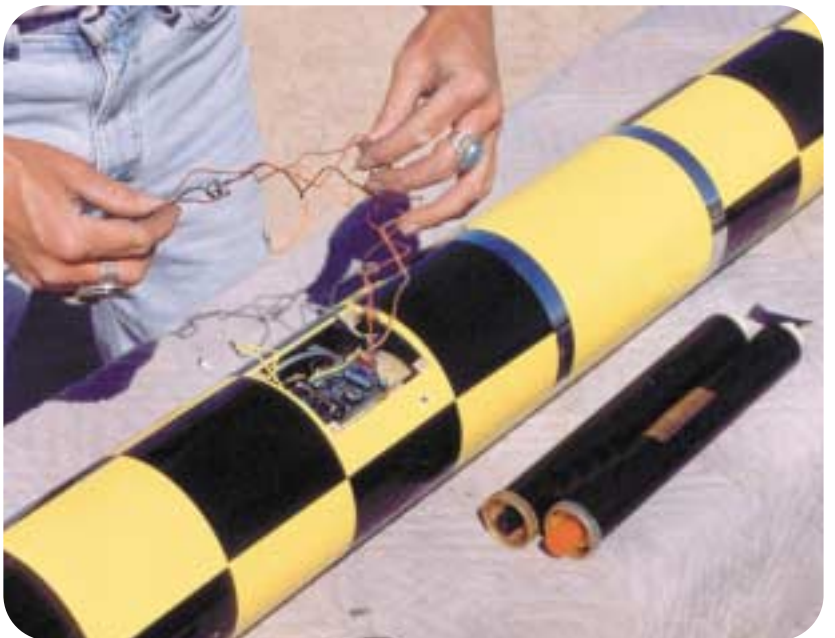



HYBRID MOTOR TECHNOLOGY

Welcome to the future! Introduced in 1995, the AeroTech RMS/Hybrid™ Reloadable Motor System became the world's first commercially available reloadable hybrid propellant rocket motor. The RMS/Hybrid is a reliable, versatile and cost-effective means of powering your high-power rocket vehicles that will grow with you as you expand your rocketry horizons. Each RMS/Hybrid motor is capable of delivering a wide range of programmable time-thrust profiles, and is easily converted to conventional solid propellant operation with AeroTech's standard RMS High Power reload kits!

A hybrid propellant rocket motor employs separated propellant ingredients in two different physical states (generally the fuel is a solid while the oxidizer is a liquid). In AeroTech's RMS/Hybrid motor design, pressurized liquefied nitrous oxide (N₂O) is employed as the oxidizer while cellulose (C₆H₁₀O₅) is utilized as the solid fuel (patent pending). Advantages of hybrid propellant technology for the high-power rocket enthusiast include markedly lower cost per flight than solid propellants, less restrictive shipping regulations and, in most cases, elimination of the need to comply with various aspects of the federal explosive laws that currently plague the purchasing and storage of large solid propellant rocket motors.

RMS/Hybrid motors use a high pressure aluminum alloy cylinder to store the liquefied nitrous oxide oxidizer prior to flight. The cylinder/valve assembly is mated to a standard RMS motor casing and aft closure via a specially designed forward closure/N₂O injector plate

assembly. The forward closure design includes a provision for a combustible Pyrovalve (patented) which restrains the flow of N₂O until the moment of ignition.

Like the original solid propellant RMS, each RMS/Hybrid precision machined anodized aluminum rocket motor can be flown again and again with easy to use RMS/Hybrid reload kits.

After purchasing one RMS/Hybrid motor, the owner can choose from a variety of thrust levels produced simply by configuring the forward closure injector plate with either 2, 3 or 4 injection ports or "jets". Owners will find the RMS/Hybrid reload kits inexpensive and easily installed in a few minutes. The nitrous oxide required for use in the RMS/Hybrid motor is widely available at auto performance shops at low cost. And the flight cylinders used for storage of N₂O are easily refilled by the user at home or at the launch site. Best of all, no special ground support equipment is required to launch rockets powered by RMS/Hybrid motors!

RMS/Hybrid motors reflect the same reliability, quality and professional design that have become the trademark of AeroTech's solid propellant RMS products. By making most of the expensive parts of the motor reusable, the cost per flight is greatly reduced. In addition, RMS motors produce far less non-biodegradable waste than single-use motors. The basic design of the RMS motors also permits performance characteristics simply not feasible with single-use motors.

Because RMS/Hybrid motors are of modular design, each reliable and durable motor can use a range of forward closure injector plate configurations and RMS/Hybrid reload kits, including the spectacular EFX and Turbo reloads! RMS/Hybrid means unprecedented user interaction, savings and enjoyment!

When you add it all together, the RMS/Hybrid is an unbeatable value combining price, quality, innovation, interaction, performance and support.



William Walby, Gary Rosenfield and Karl Bauman with William's M845HW Powered Rocket

Contents of a Typical RMS-Hybrid Reload Kit



EFX and Turbo-Hybrids use composite propellant grains to provide both extra impulse and additional exhaust effects.



EFX/Turbo-Hybrid propellant grains.

RMS/HYBRID HARDWARE DATA

RMS/Hybrid Motor Hardware Data

Hardware	Diameter	Length	Weight
RMS/Hybrid-54/1280	54mm	27.9"	902 g
RMS/Hybrid-98/5120	98mm	31.30"	2545 g

EASY ACCESS RMS/HYBRID MOTORS

RMS/Hybrid-54 Reload Kit Data

Hardware	Reload	Total Impulse	Fuel Wt.	Nitrous Oxide Wt.	Loaded Wt.
RMS/Hybrid-54/1280	J145H	880 N-sec	172 g	299 g	1497 g
RMS/Hybrid-54/1280	J170H	790 N-sec	172 g	299 g	1497 g
RMS/Hybrid-54/1280	J210H	850 N-sec	172 g	299 g	1497 g

RMS/Hybrid-54 EFX Reload Kit Data

Hardware	Reload	Total Impulse	Fuel Wt.	Nitrous Oxide Wt.	Loaded Wt.
RMS/Hybrid-54/1280	J260HW	1150 N-sec	259 g	299 g	1574 g

RMS/Hybrid-54 Turbo Reload Kit Data

Hardware	Reload	Total Impulse	Fuel Wt.	Nitrous Oxide Wt.	Loaded Wt.
RMS/Hybrid-54/1280	J390HW	1280 N-sec	391 g	299 g	1740 g

RESTRICTED ACCESS RMS/HYBRID MOTORS

RMS/Hybrid-54 Turbo Reload Kit Data

Hardware	Reload	Total Impulse	Fuel Wt.	Nitrous Oxide Wt.	Loaded Wt.
RMS/Hybrid-54/1280	K485HW	1700 N-sec	634 g	299 g	1961g

RMS/Hybrid-98 Turbo Reload Kit Data

Hardware	Reload	Total Impulse	Fuel Wt.	Nitrous Oxide Wt.	Loaded Wt.
RMS/Hybrid-98/5120	M845HW	6500 N-sec	2778 g	791 g	6833 g

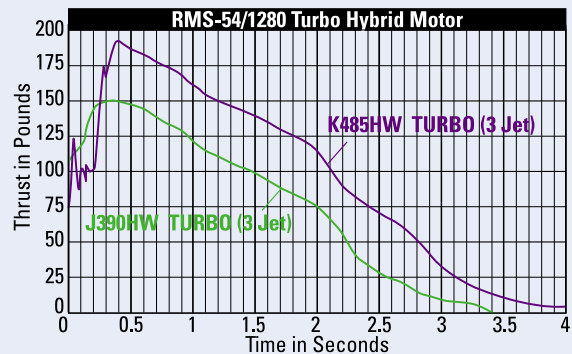
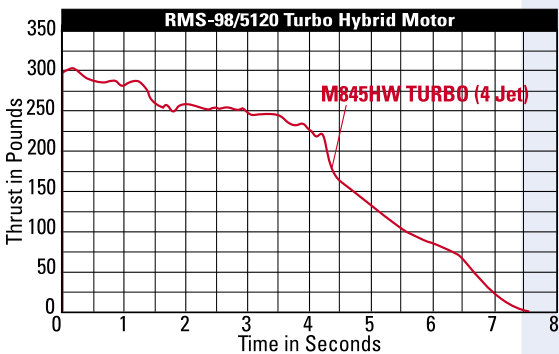
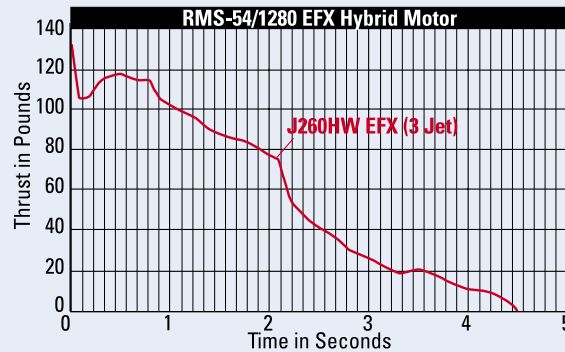
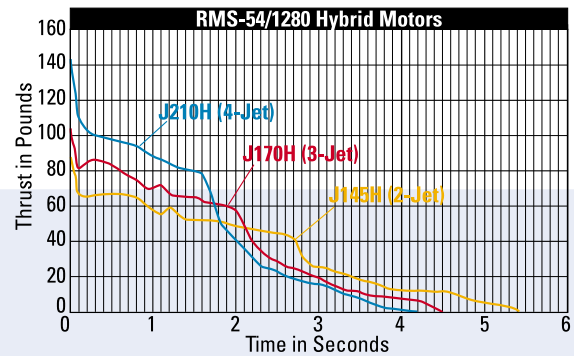

NEW INSIDE THIS CATALOG



NEW!

Specifications:

- Skill Level: 3
- Length: 39"/99cm
- Diameter: 4"/10.1 cm
- Weight: 32oz/907gms (without motor)
- Recovery System: 42" Parachute
- Nose Cone: New 9oz, grey, 4:1 ogive
- Fins: 4
- Motor Mount: 29mm
- Stages: 1

LEVEL 1 READY!

RMS Aft closure wrench



COMING IN 2001

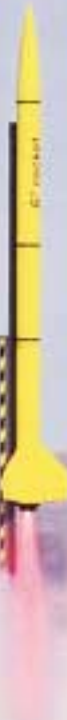
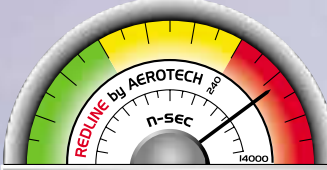



REDLINE™

Restricted Access™

- 98mm
- 75mm
- 54mm
- 38mm
- 29mm

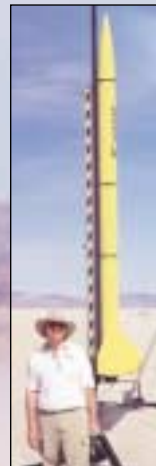
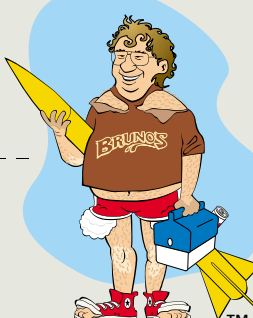
Easy Access™

OSDON

VELOCITY UNLIMITED

T · R · M

by AeroTech

FINDING A ROCKET CLUB IN YOUR AREA

Putting together a mid-power or high power rocket launch takes a lot of work. This task is generally undertaken by a rocket club for periodic organized launches. Clubs are almost mandatory for all but model rockets, but even model rocketeers benefit from club membership.

A club will have a field somewhere near the majority of their membership base where they will have periodic flights. Most model rocket clubs have flights monthly or weekly and most high-power clubs have flights less frequently (some as little as twice a year). Because the launches are periodic, most of the club will attend and this creates a social atmosphere and the launches become "events" with flyers, friends and spectators.

Another good reason to attend club launches is that the club provides the launch equipment. Launchers and ignition systems are complex and bulky and having the club provide these facilities makes it much easier to come out and fly. Also, many clubs have vendors who will sell motors (and other parts and equipment) right at the launch site. Even if you don't plan to join a club, look for a club in your area and attend a launch to see first-hand what it's all about.

Probably the best reason to join a club is the chance to learn from more experienced rocketeers. The Internet is great for gathering information, but nothing beats seeing other's rockets and showing them yours for gaining knowledge. Just seeing what other people are doing is the best way to get your own creative juices flowing and thinking about cool new things to do.

There are two basic national organizations located in the United States:

National Association of Rocketry (NAR) • www.nar.org

NAR chartered Sections are locally-organized rocket clubs. Each Section has five or more modelers, at least one of whom is an adult. Sections hold and participate in sport launches, competitions, conventions, and other local, regional, and national rocketry activities. In addition, Sections can apply to host the NAR National Competition Meet (NARAM), Sport Launch (NSL), or Convention (NARCON) at their local site.

Tripoli Rocketry Association (Tripoli) • www.tripoli.org

The Tripoli Rocketry Association, Inc. is divided into regional groups called "Prefectures". These Prefectures are like mini-organizations within an organization. They hold meetings and organize launches in their geographical area. Currently, Tripoli has Prefectures in the United States, Canada, and Europe.



AEROTECH
CONSUMER AEROSPACE

AeroTech, Inc.
1955 S. Palm St., Suite 15, Las Vegas, NV 89104
702-641-2301 • www.aerotech-rocketry.com
© 2001, AeroTech, Inc.